

GENERAL CATALOG





MANUAL



ZAZ 8.5

Inverter

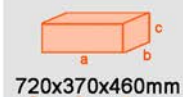

	 mm	 mm	 mm l x h
0°	85	85	105x85
45° →	65	65	60x85



MANUAL



ZAZ 10

	 mm	 mm	 mm l x h
0°	100	100	100x155
45° →	90	90	90x70

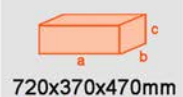



MANUAL



ZAZ 15

Inverter

	 mm	 mm	 mm l x h
0°	150	150	150x140
45° →	90	90	90x100
60° →	50	50	50x100

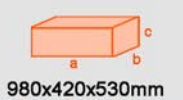
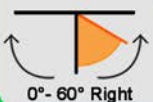

MANUAL / SEMIAUTOMATIC

ZAZ 22 SAM

230V 1PH



mm



h
mm



h
mm
l x h

0°	170	170	200x150
45° →	120	110	115x110
60° →	60	50	50x50



1,5KW



2085x20x0,9mm

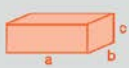

1280x510x1370mm
a b c



180kg







0°- 60° Right

MANUAL / SEMIAUTOMATIC

ZAZ 22 SAM



mm



h
mm



h
mm
l x h

0°	170	170	200x150
45° →	120	110	115x110
60° →	60	50	50x50



0,75/1,1KW



2085x20x0,9mm



1280x510x1370mm
a b c



180kg





0°- 60° Right

MANUAL / SEMIAUTOMATIC

ZAZ 27 SAM

230V 1PH



mm



h
mm



h
mm
l x h

0°	240	200	240x150
45° →	150	150	125x150
60° →	85	70	70x195



1,5KW



2455x27x0,9mm



1500x700x1600mm
a b c



220kg







0°- 60° Right

MANUAL / SEMIAUTOMATIC

ZAZ27 SAM



	 mm	 h mm	 h mm l x h
0°	240	200	240x150
45° →	150	150	125x150
60° →	85	70	70x195

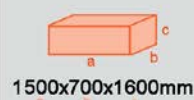



MANUAL / SEMIAUTOMATIC

M302 SAM

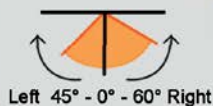
230V 1PH





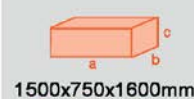

	 mm	 h mm	 h mm l x h
0°	255	240	315x190
45° →	210	190	210x160
60° →	130	130	130x160
← 45°	170	150	180x100

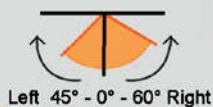

MANUAL / SEMIAUTOMATIC

M302 SAM



	 mm	 h mm	 h mm l x h
0°	255	240	315x190
45° →	210	190	210x160
60° →	130	130	130x160
← 45°	170	150	180x100

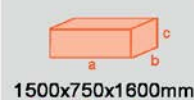

SEMI-AUTOMATIC

302 EVO



	● mm	h mm	h mm l x h
0°	255	240	315x190
45° →	210	190	210x160
60° →	130	130	130x160
← 45°	170	150	180x100



Left 45° - 0° - 60° Right



0,75/1,1KW



2825x27x0,9mm

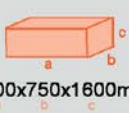

1500x750x1600mm



425kg

SEMI-AUTOMATIC

302 EVO *Inverter*



	● mm	h mm	h mm l x h
0°	255	240	315x190
45° →	210	190	210x160
60° →	130	130	130x160
← 45°	170	150	180x100



Left 45° - 0° - 60° Right



0,75/1,1KW



2825x27x0,9mm

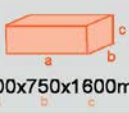

1500x750x1600mm



425kg

RF 300-L



mm 2000



mm 300



kg/m 250

RVM 300-L

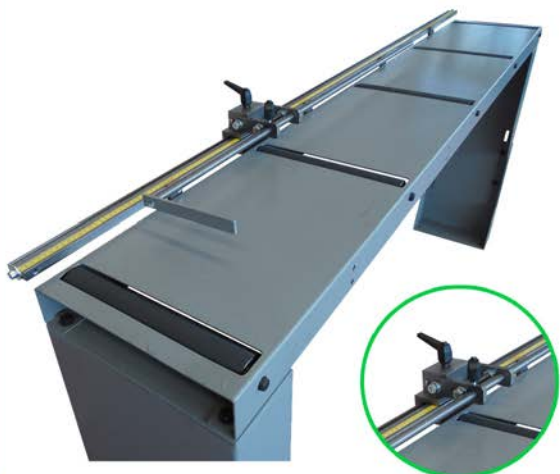

mm 2000



mm 300



kg/m 250

RCN 300-L



mm 2000
4000
6000



mm 300



kg/m 250



SEMI-AUTOMATIC

MAX 460G EVO



	 mm	 h mm	 h mm l x h
0°	330	330	460x250
45° →	300	300	300x250
60° →	200	200	200x200
← 45°	300	300	300x250

 Left 45° - 0° - 60° Right

 1,5/2,2KW

 3960x34x1,1mm

 920x2000x1500mm

 820kg

SEMI-AUTOMATIC

MAX 460G EVO *Inverter*



	 mm	 h mm	 h mm l x h
0°	330	330	460x250
45° →	300	300	300x250
60° →	200	200	200x200
← 45°	300	300	300x250

 Left 45° - 0° - 60° Right

 1,5/2,2KW

 3960x34x1,1mm





 920x2000x1500mm



 820kg

SEMI-AUTOMATIC

MAX 620G EVO *Inverter*



	 mm	 h mm	 h mm l x h
0°	500	500	620x500
45° →	450	450	450x500
60° →	310	310	310x500
← 45°	450	420	440x380

 Left 60° - 0° - 60° Right

 3 KW

 5250x41x1.3

 1450x2850x1495mm

 1300kg

RF 600-L



mm 2000



mm 600



kg/m 500

RVM 600-L

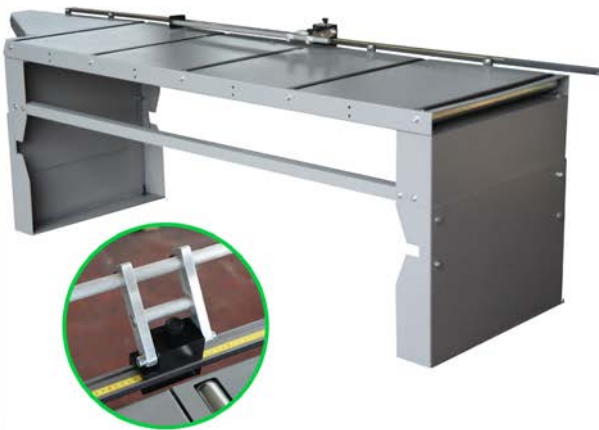

mm 2000



mm 600



kg/m 500

RCN 600-L



mm 2000
4000
6000



mm 600



kg/m 500













PLASMA

PLASMA TaJo



Duty Cycle 80%

	TaJo 45	TaJo 65	TaJo 85	TaJo 105	TaJo 125
	340-460 Vac 3 Ph 50-60 Hz	340-460 Vac 3 Ph 50-60 Hz	340-460 Vac 3 Ph 50-60 Hz	340-460 Vac 3 Ph 50-60 Hz	340-460 Vac 3 Ph 50-60 Hz
	7.6 KVA	11.9 KVA	15.5 KVA	19.3 KVA	25.6 KVA
	80 %	80 %	80 %	80 %	80 %
	12 mm	15 mm	18 mm	22 mm	25 mm
	20 mm	30 mm	40 mm	50 mm	60 mm
	15 mm	25 mm	35 mm	45 mm	55 mm
	12 mm	15 mm	25 mm	35 mm	45 mm
	180 L/min	180 L/min	180 L/min	200 L/min	200 L/min
	230x610x450mm	230x655x450mm	230x655x450mm	230x810x500mm	270x810x500mm
	16 Kg	28 Kg	29 Kg	42 Kg	44 Kg



SEMI-AUTOMATIC

600/800 SA

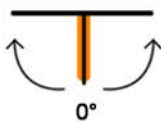

mm



mm

 mm
l x h

0°

600

600

800x600



7150x41x1,3mm



4/5KW

 3700x2130x2450mm
a b c

3000kg

SEMI-AUTOMATIC

600/800 G

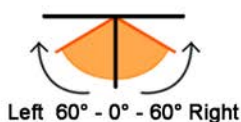

mm



mm

 mm
l x h

0°

600

600

800x600

45° →

550

550

550x600

60° →

350

350

350x550

← 45°

550

550

550x500

← 60°

250

250

250x500



7150x41x1,3mm

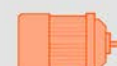

4/5KW

 3700x2130x2450mm
a b c

3400kg

SEMI-AUTOMATIC

600/1200 SA

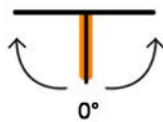

mm



mm



mm
l x h

0°	600	600	1200x600
----	-----	-----	----------



7880x41x1,3mm



4/5KW



4470x2130x2550mm
a b c



3600kg

SEMI-AUTOMATIC

600/1200 G



Left 60° - 0° - 60° Right



mm



mm



mm
l x h

0°	600	600	1200x600
45° →	600	600	800x600
60° →	550	550	550x600
← 45°	600	600	600x800
← 60°	440	440	440x600



7880x41x1,3mm



4/5KW



4470x2150x2550mm
a b c



3600kg

SEMIAUTOMATIC

800/1000 SA

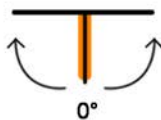

mm



h

mm



h

mm

l x h

0°

800

800

1000x800



10150x54x1,6mm



7,5KW



5800x2500x3200mm



11500kg

SEMIAUTOMATIC

800/1000 G

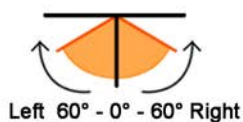

mm



h

mm



h

mm

l x h

0°

800

800

1000x800

45° →

580

580

580x800

60° →

220

220

220x800

← 45°

580

580

580x800

← 60°

280

280

280x800



10150x54x1,6mm

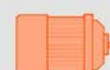

7,5KW



5800x4200x3200mm



13000kg

SEMI-AUTOMATIC

800/1500 SA

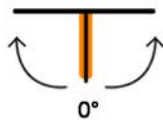

mm



mm



mm
l x h

0°	800	800	1500x800
----	-----	-----	----------



11100x54x1,6mm



7,5KW



6300x2500x3200mm
a b c



13000kg

SEMI-AUTOMATIC

800/1500 G

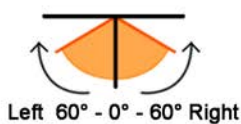

mm



mm



mm
l x h

0°	800	800	1500x800
45° →	800	800	940x800
60° →	470	470	470x800
← 45°	800	800	940x800
← 60°	580	580	580x800



11100x54x1,6mm



7,5KW



6300x4200x3200mm
a b c





14500kg

AUTOMATIC

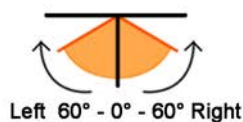
MAX 620 GA



	 mm	 mm	 mm
		l	l x h
0°	400	400	400x400
45° →	400	400	400x400
60° →	280	280	280x380
← 45°	400	400	400x400
← 60°	280	280	280x380



5250x41x1,3mm



3KW



4800x2600x1600mm





3200kg

AUTOMATIC

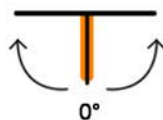
260A e-power



	 mm	 mm
0°	260	260



4200x34x1.1mm



4KW



2280x1930x1940mm



2400Kg

AUTOMATIC

360A41 e-power

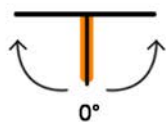

mm



mm

0°	360	360
----	-----	-----



5300x41x1.3mm



4-5KW



2970x1690x2140mm



2900Kg

AUTOMATIC

360A41 e-power SD



3KW

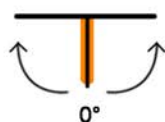

mm



mm

0°	360	360
----	-----	-----



5300x41x1.3mm



4-5KW

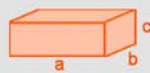

2970x1690x2140mm



3300Kg

AUTOMATIC



460A41 e-power



0°	460	460
----	-----	-----

5300x41x1.3mm

4-5KW

2970x1690x2140mm

3000Kg

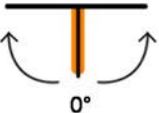

AUTOMATIC



460A41 e-power SD

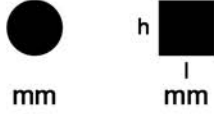

0°	460	460
----	-----	-----

5300x41x1.3mm

4-5KW

2970x1690x2140mm

3400Kg

3KW

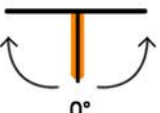

AUTOMATIC

606A41 e-power

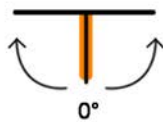

mm



h

mm

0°

600

600



6020x41x1.3mm



5KW



3190x2000x2450mm



3200Kg

AUTOMATIC

444A PLUS

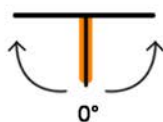

mm



h

mm



h

mm

0°

450

450

450x550



5890x41x1.3mm



5-7.5KW



4000x1860x2700mm



4400Kg

AUTOMATIC

555A PLUS

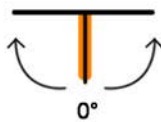

mm



h

mm



h

mm

0°

550

550

550x550



7860x54x1.6mm



7.5-9KW



4400x2000x2500mm



5000Kg

AUTOMATIC

600A PLUS

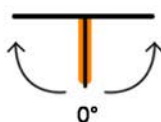

mm



h

mm



h

mm

0°

620

620

620x620



8800x67x1.6mm



11KW



4900x2600x2850mm



6700Kg

AUTOMATIC

850A

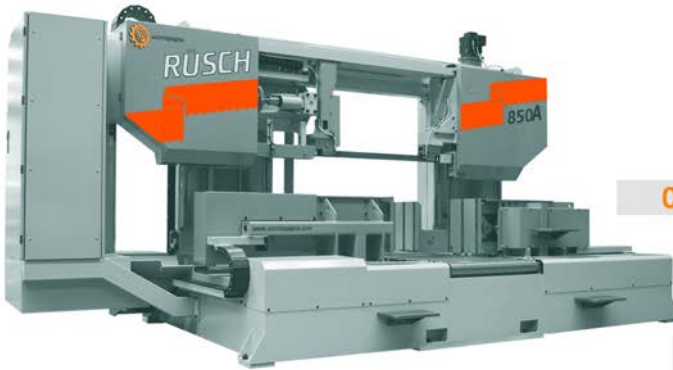

mm

h



mm

h



mm
l x h

0°

900

850

900x850



10150x80x1,6mm



40Nm

OPT.



10150x67x1,6mm



6750x3000x3180mm



13500kg

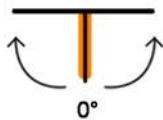

0°

AUTOMATIC

1100-1260A

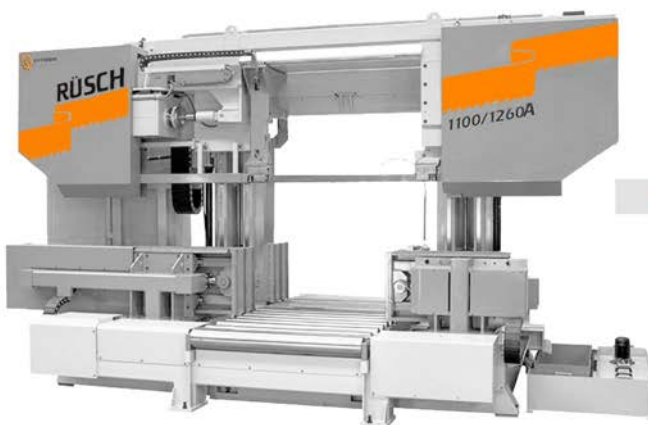

mm

h



mm

h



mm
l x h

0°

1160

1160

1320x1160



13650x80x1,6mm



22KW

OPT.



13650x67x1,6mm



6690x3130x3590mm



20000kg

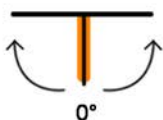

0°

CAR-T**CAR-C****CAR-H****CAR-CL**

600/800A 2000

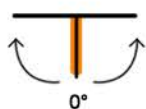

mm



mm

0°

600

600



7150x41x1,3mm



5KW



3700x3130x2450mm



4200kg

RF 450-P



mm 1000/
2000/
3000



mm 450



kg/m 2000

RF 600-P



mm 1000/
2000/
3000



mm 600



kg/m 2000

RF 800-P



mm 1000/
2000/
3000



mm 800



kg/m 2000

DRILLING MACHINE

RDU 303-600

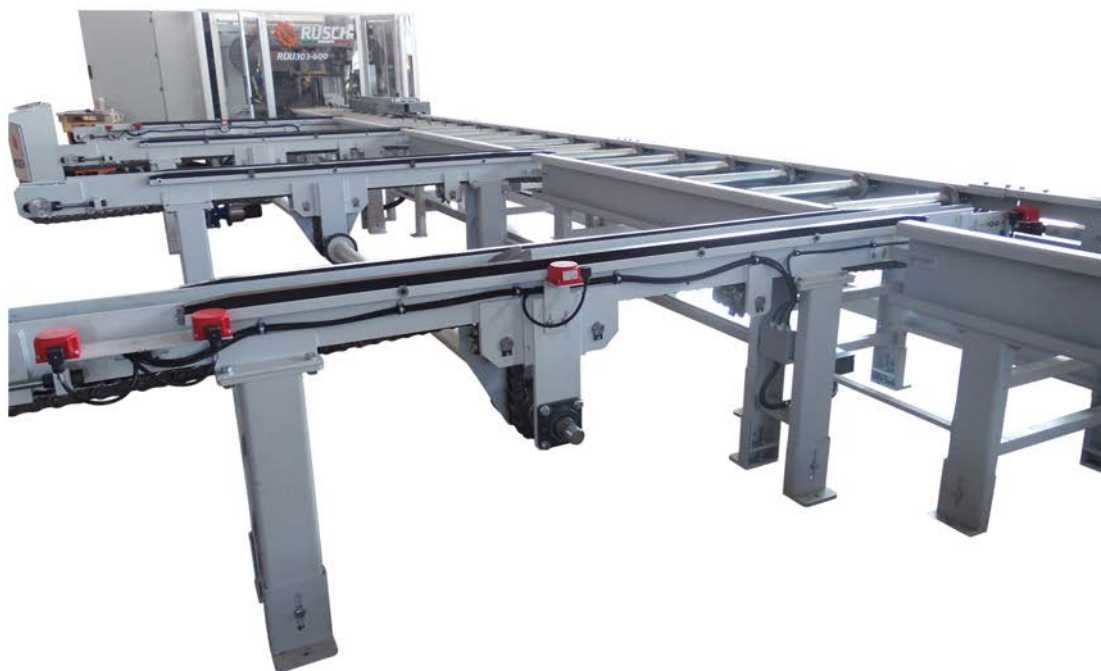

DRILLING MACHINE

RDU 403-600/1000/1500/2000



PLASMA

PLASMA KoLo

KoLo 15-30 1500x3000mm

KoLo 20-40 2000x4000mm

KoLo 20-60 2000x6000mm



PLASMA - DRILL TAP - MILL

*Larghezza 2 - 6mt.
Lunghezza 3 - 50mt.*

RAPTOR

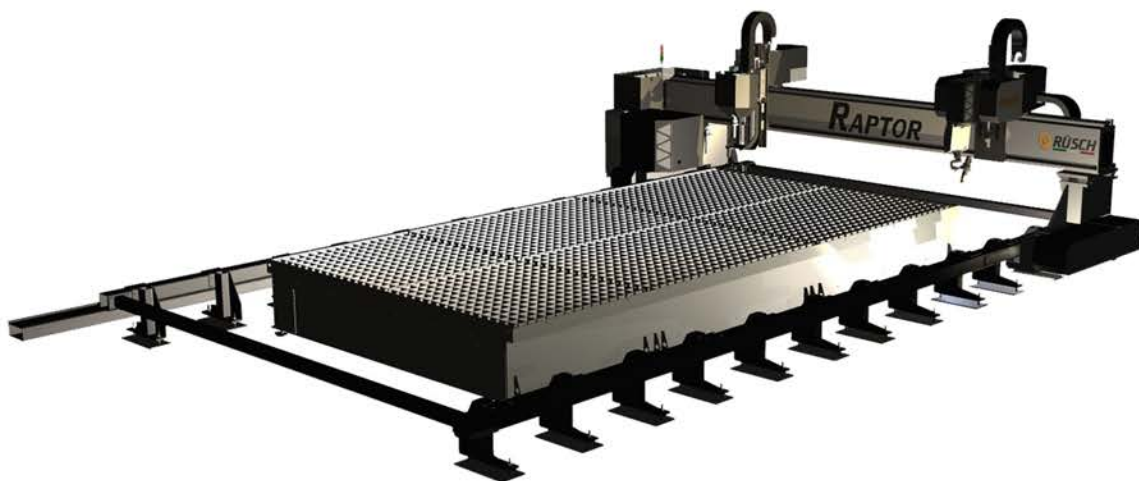

HSK 63A



BEVEL



170/300A



30KW

PLASMA

RoboRaptor 3D Plasma



ROBOTIC CELLS



Pick and Place Cells
Plasma Cutting Cells
Welding Cells
Painting Cells
Milling and Conturing Cells
Polishing Cells
3D Printing Cells

BLADES



CUTTING INSTITUTE



SERVICE





Via Marco Corner 4
36016 Thiene VI
Italy
Tel +39 0445 320101
Fax +39 0445 320250
info@rusch.eu
www.rusch.eu